

## Bridge Guides

Series B01 bridge guides are compact guide units with integrated ball bearings or plain bushings, for operating LinMot P01 linear motors with high-clearance sliders. The rear end plate increases the mechanical stiffness of the bridge guide.

Bridge Guides are used as load bearings, to resist external forces and rotational and bending moments, and as an anti-rotation device. They provide high-precision guidance and allow dynamic and precise positioning of the load.

The load is mounted directly to the front plate of the linear guide. Mechanical dimensions and mounting options are compatible with pneumatic linear guides. The modular design allows simple addition of accessories, such as a mechanical brake or magnetic spring, for load balancing in vertical applications.

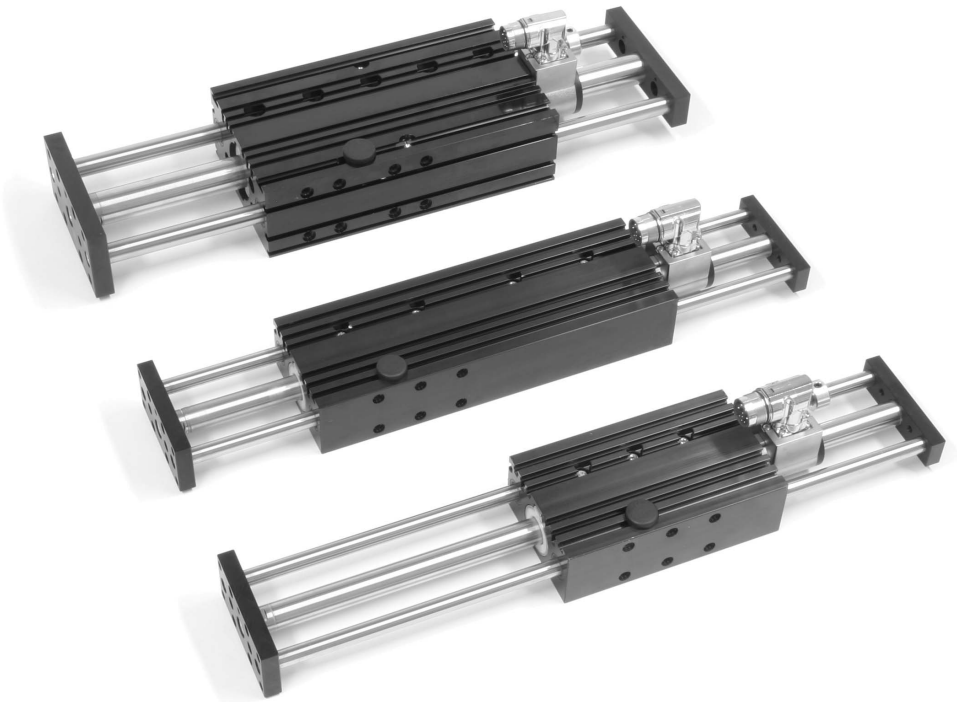

Designation:

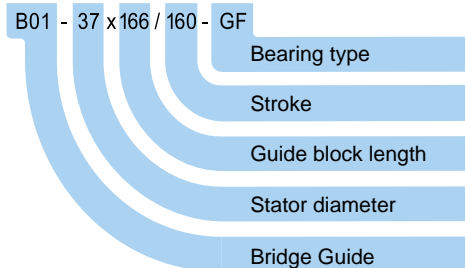

### Mechanical Compatibility

LinMot B01 bridge guides are mechanically compatible with pneumatic H-guides.

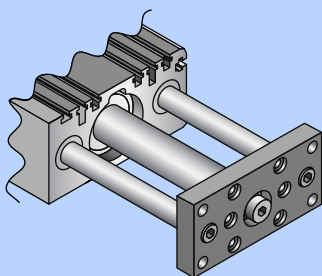

This allows simple replacement with a new drive technology, if more flexibility or higher dynamics are required.

### Ball Bearings

Use of linear guides with ball bearings is recommended for standard applications under normal environmental conditions.

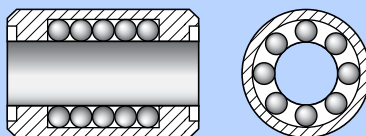

Linear guides with ball bearings have very good running characteristics, and ensure nearly frictionless operation.

### Sintered Bushing

For applications in very dirty, damp, or wet environments, the use of linear guides with bushing and stainless steel shafts is recommended.

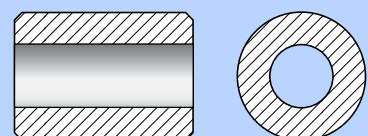

For highly dynamic applications with accelerations over 50 m/s<sup>2</sup>, the use of bridge modules with Plain Bushings is also recommended.

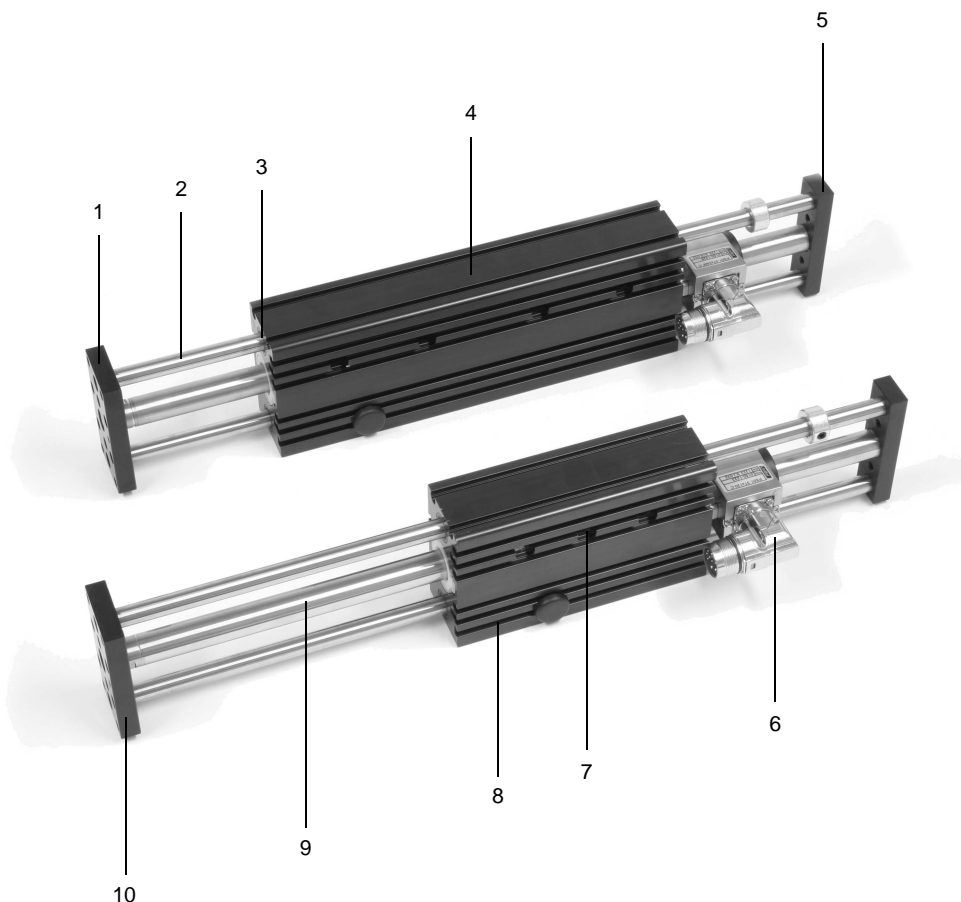

1. Mounting plate with counter bore for precise load mounting
2. Hardened or stainless steel shafts for precise positioning and quiet operation.
3. Ball bearings or plain bushings, for high load masses and long life
4. Guide block with counter bores for uncomplicated, precise mounting of the Bridge Module.
5. Mechanical end stop (rear).
6. Linear motor stator with integrated bearings, temperature and position sensors. Available with IP67 connector housing or cable exit.
7. Clamping cylinder to secure the stator in the guide block.
8. T-slots in the guide block allow simple mounting of accessories.
9. Linear motor slider, guarantees maximum force and precise positioning.
10. Integrated linear coupling for simple mounting of the slider.

## Bridge Module BM01

Complete BM01 bridge modules, consisting of a B01 bridge guide and P01 linear motor, are highly dynamic design components. Compact construction and free positioning have significant advantages, especially in textile and packaging machines, assembly and feeding technology, laboratory automation, and special machines and systems.



Designation:

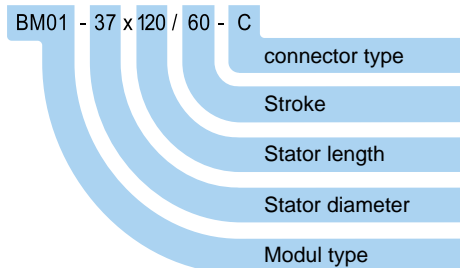

### Brake Option

As an option, B01-37 (600N Holding Force) and B01-48 (1000N) guides can have a mechanical brake attached.

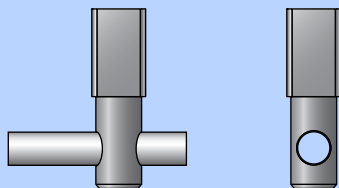

The pneumatic brake is controlled by the E1100 Servo Drive. The brake acts on the guide shafts of the linear guide, and is released under air pressure (4-6 bar). With no air pressure, the brake is on.

### MagSpring Option

In vertical applications, a MagSpring can be used as a weight balancer.

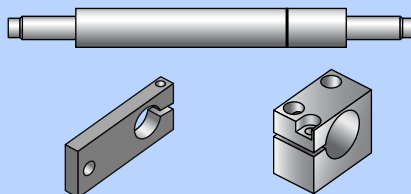

The MagSpring also prevents the linear motor from falling to the lower end stop if the linear motor is turned off or the power is lost. Appropriate accessories are available for mounting the magnetic spring.

### Fan Option

With an additional fan, the holding force of the linear motor can be nearly doubled.

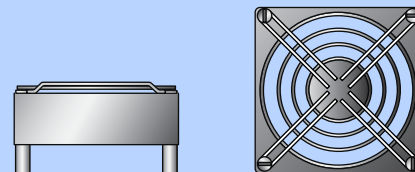

If needed, the optional fan can be mounted directly on the guide.



## Positioning Times with BM01-37x120

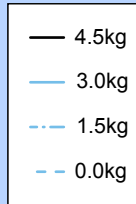
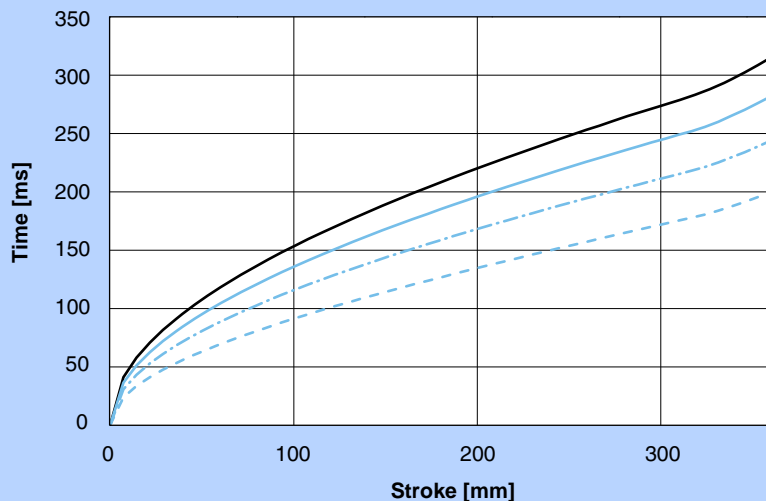

Minimum positioning times for horizontal motions with different load masses, controlled by an E1100-HC Servo Drive.

## Ordering Information

BM01-37x120/160		Bridge Module 37x120 with 160mm stroke <sup>1)</sup>		
Bridge Guide	B01-37x166/160	B01 for P01-37x120, 160mm stroke, Ball Bearings		0150-5138
	B01-37x166/160-GF	B01 for P01-37x120, 160mm stroke, Plain Bushings		0150-5141
Stator	PS01-37x120-C	Linear motor stator, connector type C - IP67		0150-1223
	PS01-37x120-C20	Linear motor stator, 0.2m Cable, connector C - IP67		0150-1237
	PS01-37x120	Linear motor stator, 1.5m Cable, connector P		0150-1204
Slider	PL01-19x395/320	High clearance slider for B01-37x166/160		0150-1452

BM01-37x120/260		Bridge Module 37x120 with 260mm stroke <sup>1)</sup>		
Bridge Guide	B01-37x166/260	B01 for P01-37x120, 260mm stroke, Ball Bearings		0150-5139
	B01-37x166/260-GF	B01 for P01-37x120, 260mm stroke, Plain Bushings		0150-5142
Stator	PS01-37x120-C	Linear motor stator, connector type C - IP67		0150-1223
	PS01-37x120-C20	Linear motor stator, 0.2m Cable, connector C - IP67		0150-1237
	PS01-37x120	Linear motor stator, 1.5m Cable, connector P		0150-1204
Slider	PL01-19x500/420	High clearance slider for B01-37x166/260		0150-1455

BM01-37x120/360		Bridge Module 37x120 with 360mm stroke <sup>1)</sup>		
Bridge Guide	B01-37x166/360	B01 for P01-37x120, 360mm stroke, Ball Bearings		0150-5140
	B01-37x166/360-GF	B01 for P01-37x120, 360mm stroke, Plain Bushings		0150-5143
Stator	PS01-37x120-C	Linear motor stator, connector type C - IP67		0150-1223
	PS01-37x120-C20	Linear motor stator, 0.2m Cable, connector C - IP67		0150-1237
	PS01-37x120	Linear motor stator, 1.5m Cable, connector P		0150-1204
Slider	PL01-19x600/520	High clearance slider for B01-37x166/360		0150-1456

Accessories				
Brake	HB01-37	Pneumatic Brake for B01-37 / 600N (4-6 Bar)		0150-5052
Fan	HV01-37/48	Fan for H01-37 und -48 Linear Guides		0150-5051
MagSpring	MF01-37/H37	Mounting flange for MagSpring M01-37x...		0250-2307
	MA01-37/H37	Mounting adapter for MagSpring M01-37x...		0250-0117
Center Sleeve	HC01-09/04	Center Sleeve D9x4mm		0150-3251
Wiper	HA01-37/19-F	Wiper for B01-37 guides, front side		0150-5177

<sup>1)</sup> The stroke is reduced by 18mm when using cable models

## Bridge Module BM01-37x240

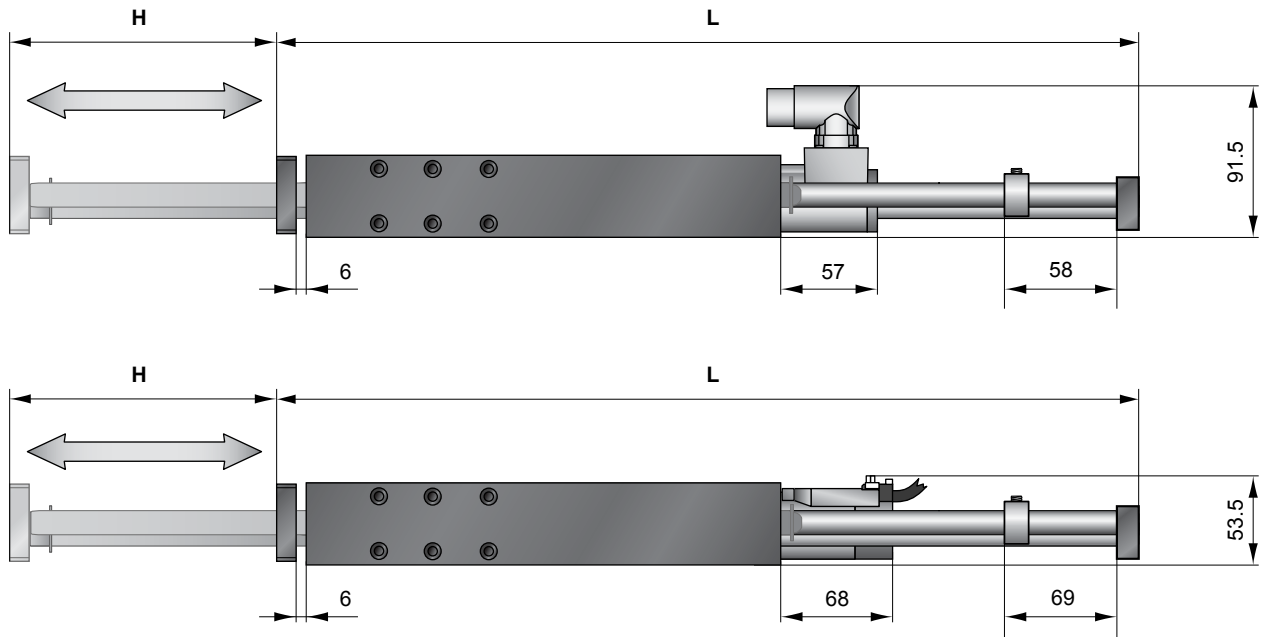

Bridge Module	Bearing	Stroke H <sup>1)</sup> [mm (inch)]	Moving Parts L [mm (inch)]	Moving Mass <sup>2)</sup> [g (lb)]	Total Weight <sup>2)</sup> [g (lb)]
BM01-37x240/140	Ball Bearings	140 (5.51)	510 (20.08)	1820 (4.01)	5500 (12.11)
BM01-37x240/240	Ball Bearings	240 (9.45)	610 (24.02)	2210 (4.87)	5900 (12.97)
BM01-37x240/340	Ball Bearings	340 (13.39)	710 (27.95)	2600 (5.71)	6300 (13.81)
BM01-37x240/140-GF	Plain Bushings	140 (5.51)	510 (20.08)	1820 (4.01)	5500 (12.11)
BM01-37x240/240-GF	Plain Bushings	240 (9.45)	610 (24.02)	2210 (4.87)	5900 (12.97)
BM01-37x240/340-GF	Plain Bushings	340 (13.39)	710 (27.95)	2600 (5.71)	6300 (13.81)

<sup>1)</sup> The stroke is reduced by 18mm when using cable models

<sup>2)</sup> bridge guide with linear motor

## Bridge Guides B01-37x286

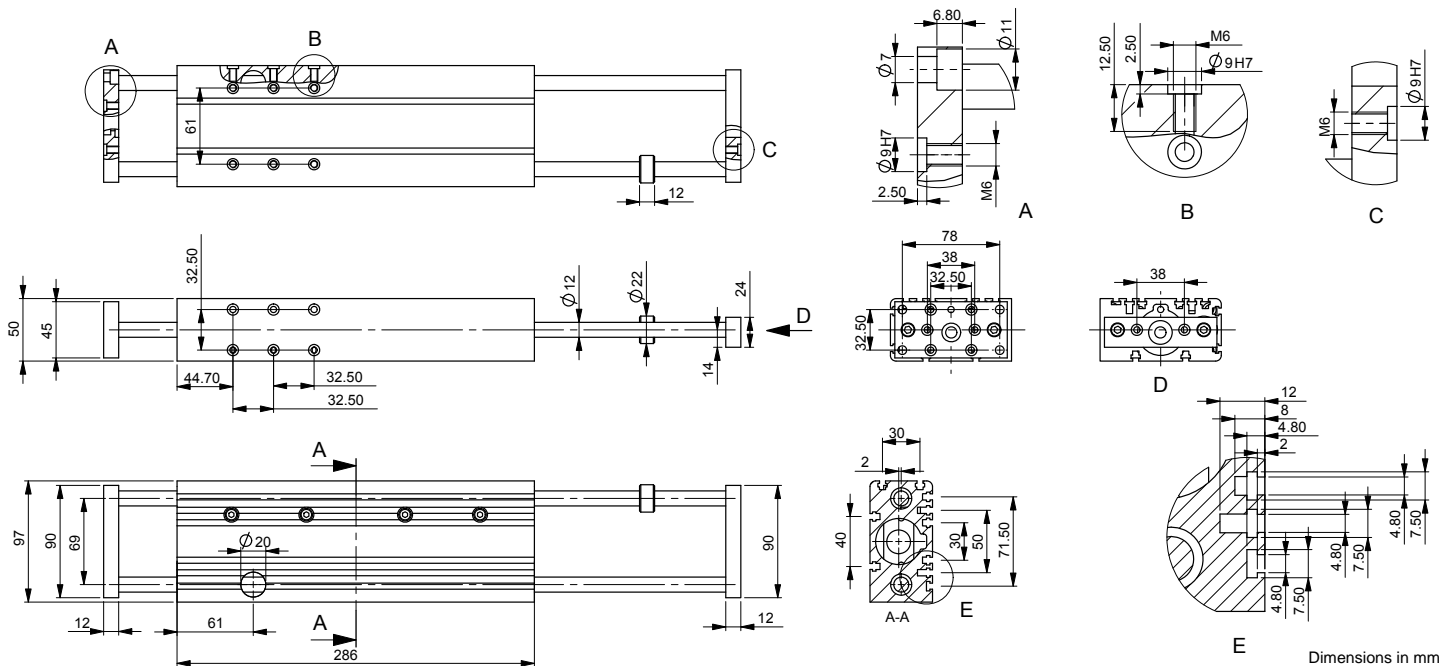

Materials	Guide Block & Front Plate	Guide Shaft	Bearing	Wipers	
B01-37x286/...	Ball Bearings	Anodized Aluminum	Hardened Steel	Steel	Nitrile Rubber
B01-37x286/...-GF	Plain Bushings	Anodized Aluminum	Stainless Steel 1.4104	Sintered Bronze	Nitrile Rubber

## Positioning Times with BM01-37x240

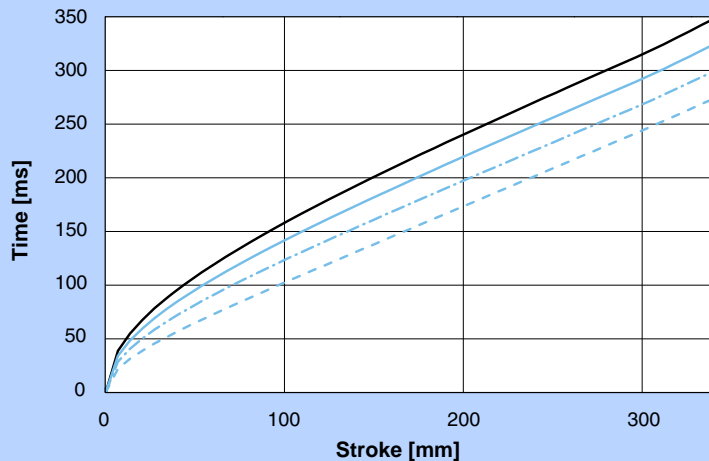

Minimum positioning times for horizontal motions with different load masses, controlled by an E1100-HC Servo Drive.

## Ordering Information

BM01-37x240/140		Bridge Module 37x240 with 140mm stroke <sup>1)</sup>			
Bridge Guide	B01-37x286/140	B01 for P01-37x240, 140mm stroke, Ball Bearings		0150-5144	
	B01-37x286/140-GF	B01 for P01-37x240, 140mm stroke, Plain Bushings		0150-5147	
Stator	PS01-37x240-C	Linear motor stator, connector type C - IP67		0150-1224	
	PS01-37x240F-C	Linear motor stator, connector type C - IP67	Fast Winding	0150-1225	
	PS01-37x240-C20	Linear motor stator, 0.2m Cable, connector C - IP67		0150-1238	
	PS01-37x240F-C20	Linear motor stator, 0.2m Cable, connector C - IP67	Fast Winding	0150-1239	
	PS01-37x240	Linear motor stator, 1.5m Cable, connector P		0150-1203	
Slider	PL01-19x500/420	High clearance slider B01-37x286/140		0150-1455	

BM01-37x240/240		Bridge Module 37x240 with 240mm stroke <sup>1)</sup>			
Bridge Guide	B01-37x286/240	B01 for P01-37x240, 240mm stroke, Ball Bearings		0150-5145	
	B01-37x286/240-GF	B01 for P01-37x240, 240mm stroke, Plain Bushings		0150-5148	
Stator	PS01-37x240-C	Linear motor stator, connector type C - IP67		0150-1224	
	PS01-37x240F-C	Linear motor stator, connector type C - IP67	Fast Winding	0150-1225	
	PS01-37x240-C20	Linear motor stator, 0.2m Cable, connector C - IP67		0150-1238	
	PS01-37x240F-C20	Linear motor stator, 0.2m Cable, connector C - IP67	Fast Winding	0150-1239	
	PS01-37x240	Linear motor stator, 1.5m Cable, connector P		0150-1203	
Slider	PL01-19x600/520	High clearance slider B01-37x286/240		0150-1456	

BM01-37x240/340		Bridge Module 37x240 with 340mm stroke <sup>1)</sup>			
Bridge Guide	B01-37x286/340	B01 for P01-37x240, 340mm stroke, Ball Bearings		0150-5146	
	B01-37x286/340-GF	B01 for P01-37x240, 340mm stroke, Plain Bushings		0150-5149	
Stator	PS01-37x240-C	Linear motor stator, connector type C - IP67		0150-1224	
	PS01-37x240F-C	Linear motor stator, connector type C - IP67	Fast Winding	0150-1225	
	PS01-37x240-C20	Linear motor stator, 0.2m Cable, connector C - IP67		0150-1238	
	PS01-37x240F-C20	Linear motor stator, 0.2m Cable, connector C - IP67	Fast Winding	0150-1239	
	PS01-37x240	Linear motor stator, 1.5m Cable, connector P		0150-1203	
Slider	PL01-19x700/620	High clearance slider for B01-37x286/340		0150-1457	

## Accessories

Brake	HB01-37	Pneumatic Brake for B01-37 / 600N (4-6 Bar)		0150-5052
Fan	HV01-37/48	Fan for H01-37 und -48 Linear Guides		0150-5051
MagSpring	MF01-37/H37	Mounting flange for MagSpring M01-37x...		0250-2307
	MA01-37/H37	Mounting adapter for MagSpring M01-37x...		0250-0117
Center Sleeve	HC01-09/04	Center Sleeve D9x4mm		0150-3251
Wiper	HA01-37/19-F	Wiper for B01-37 guides, front side		0150-5177

<sup>1)</sup> The stroke is reduced by 18mm when using cable models





## Positioning Times with BM01-48x240

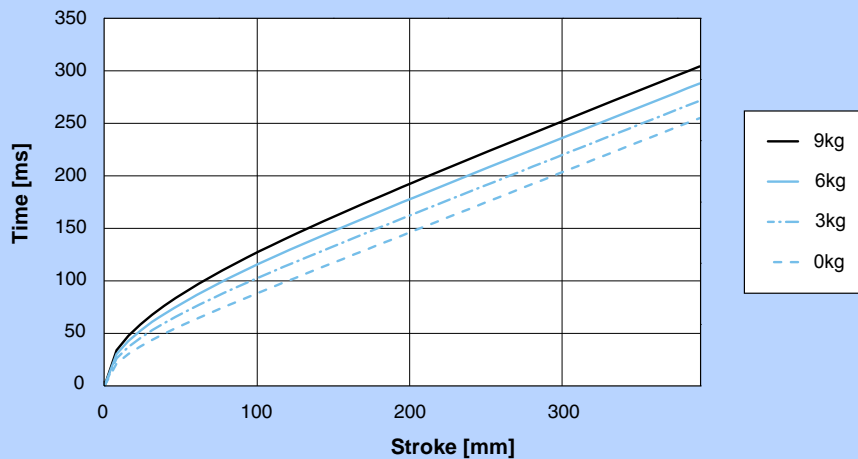

Minimum positioning times for horizontal motions with different load masses, controlled by an E1100-HC Servo Drive.

## Ordering Information

BM01-48x240/90		Bridge Module 48x240 with 90mm stroke			
Bridge Guide	B01-48x250/90	B01 for P01-48x240, 90mm stroke, Ball Bearings			0150-5150
	B01-48x250/90-GF	B01 for P01-48x240, 90mm stroke, Plain Bushings			0150-5154
Stator	PS01-48x240-C	Linear motor stator, connector type C - IP67			0150-1219
	PS01-48x240F-C	Linear motor stator, connector type C - IP67	Fast Winding		0150-1220
Slider	PL01-27x410/330	High clearance slider for B01-48x250/90			0150-1468

BM01-48x240/180		Bridge Module 48x240 with 180mm stroke			
Bridge Guide	B01-48x250/180	B01 for P01-48x240, 180mm stroke, Ball Bearings			0150-5151
	B01-48x250/180-GF	B01 for P01-48x240, 180mm stroke, Plain Bushings			0150-5155
Stator	PS01-48x240-C	Linear motor stator, connector type C - IP67			0150-1219
	PS01-48x240F-C	Linear motor stator, connector type C - IP67	Fast Winding		0150-1220
Slider	PL01-27x500/420	High clearance slider for B01-48x250/180			0150-1469

BM01-48x240/300		Bridge Module 48x240 with 300mm stroke			
Bridge Guide	B01-48x250/300	B01 for P01-48x240, 300mm stroke, Ball Bearings			0150-5152
	B01-48x250/300-GF	B01 for P01-48x240, 300mm stroke, Plain Bushings			0150-5156
Stator	PS01-48x240-C	Linear motor stator, connector type C - IP67			0150-1219
	PS01-48x240F-C	Linear motor stator, connector type C - IP67	Fast Winding		0150-1220
Slider	PL01-27x620/540	High clearance slider for B01-48x250/300			0150-1470

BM01-48x240/390		Bridge Module 48x240 with 390mm stroke			
Bridge Guide	B01-48x250/390	B01 for P01-48x240, 390mm stroke, Ball Bearings			0150-5153
	B01-48x250/390-GF	B01 for P01-48x240, 390mm stroke, Plain Bushings			0150-5157
Stator	PS01-48x240-C	Linear motor stator, connector type C - IP67			0150-1219
	PS01-48x240F-C	Linear motor stator, connector type C - IP67	Fast Winding		0150-1220
Slider	PL01-27x710/630	High clearance slider for B01-48x250/390			0150-1471

## Accessories

Brake	HB01-48	Pneumatic Brake for B01-48 / 1000N (4-6 Bar)		0150-5098
Fan	HV01-37/48	Fan for B01-37 and -48 bridge guides		0150-5051
MagSpring	MF01-37/H37	Mounting flange for MagSpring M01-37x...		0250-2307
	MA01-37/H48	Mounting adapter for MagSpring M01-37x...		0250-0118
Sliding Block	PFN01-8/M6	Sliding Block 8mm with M6 Thread		0150-3245
Center Sleeve	HC01-11/05	Center Sleeve D11x5mm		0150-3252
Wiper	HA01-48/27-F	Wiper for B01-48 guides, front side		0150-5178



## Maximum Load

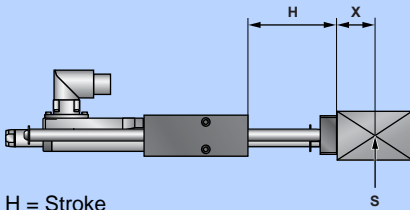

H = Stroke  
 X = Distance to center of gravity  
 S = Center of gravity

Cantilever extension =  $H + X$

The maximum load depends on the cantilever extension (maximum stroke A plus distance between the center of gravity of the working load and the mounting surface).

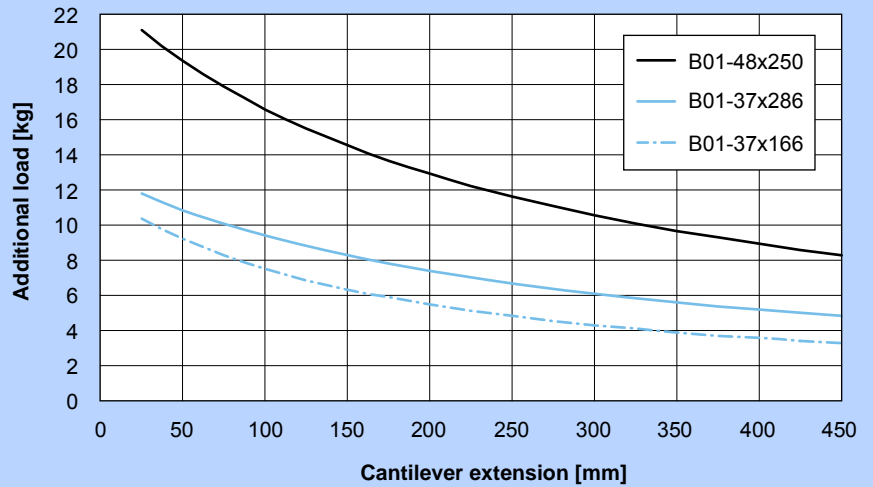

## Vertical Deflection

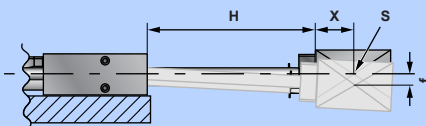

H = Stroke  
 X = Distance to center of gravity  
 S = Center of gravity  
 f = Deflection of theoretical axis

Total deflection = static deflection + deflection under load

Deflection measured at standstill, with 10 N / 2.25 lbf load.

Deflection for smaller or larger load masses can be linearly extrapolated using the data for 10 N / 2.25 lbf.

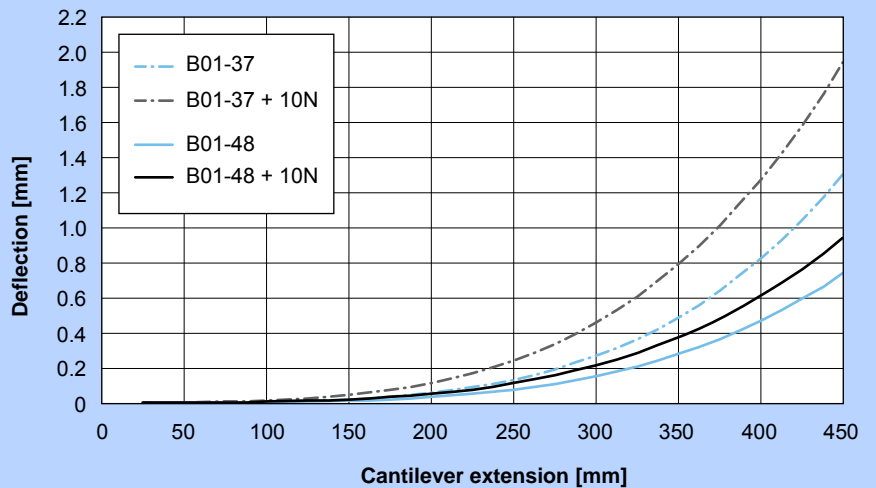

## Angular Deflection

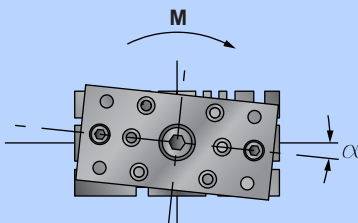

Angular deflection (twist) of the mounting plate depends on the torque load to be absorbed and the cantilever extension.

The angular deflection for smaller or larger torques can be linearly extrapolated from the deflection in the diagram.

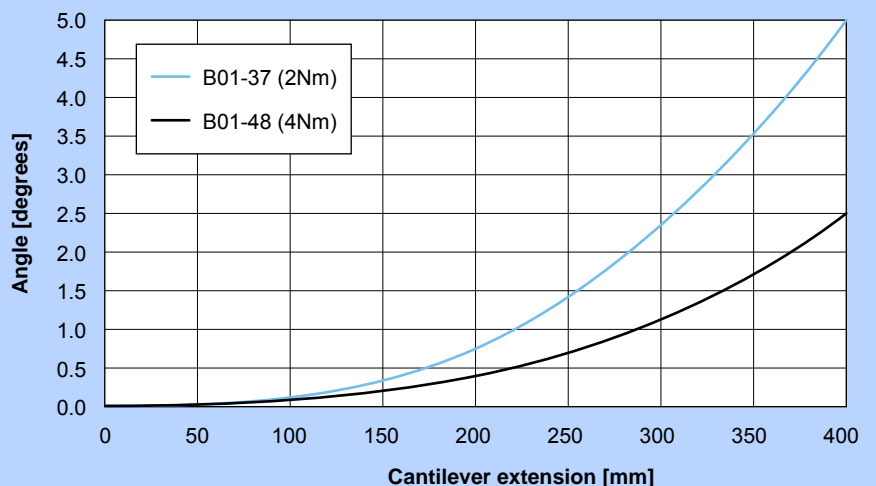

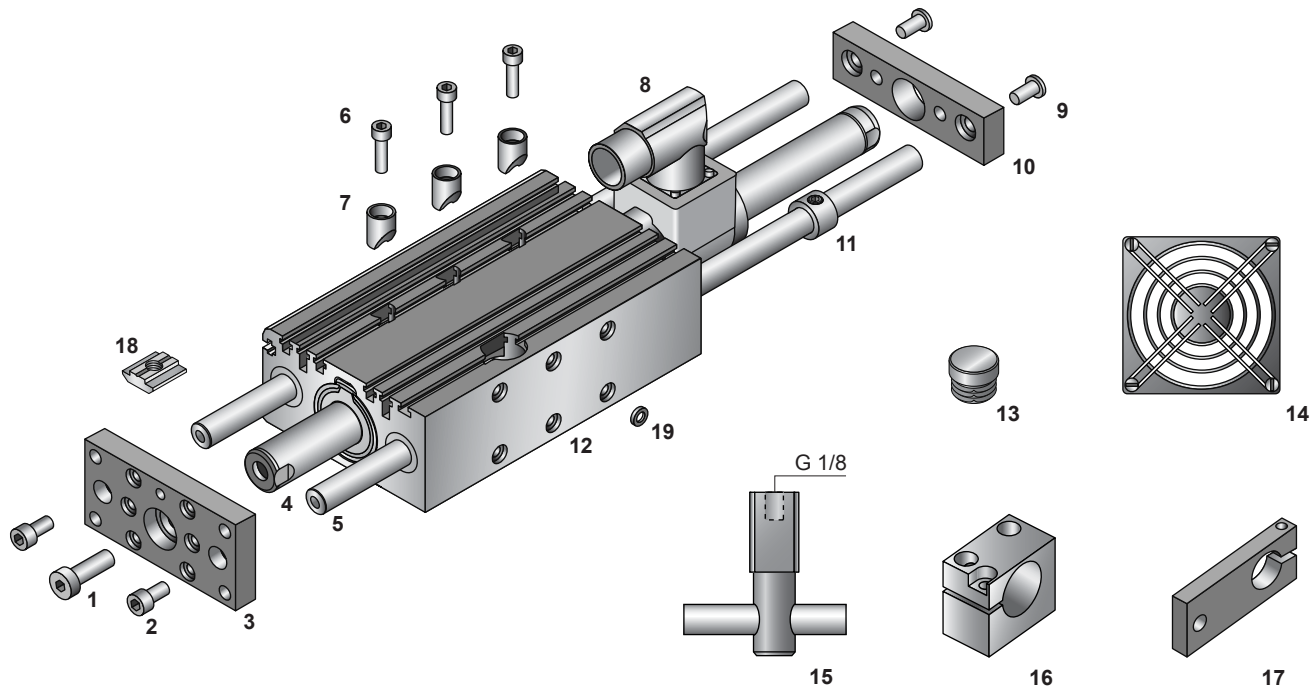

Parts List				
Bridge Guide	B01-37x166	B01-37x286	B01-48x250	
1	Slider screw	ISO 4762 M5x18	DIN7984 M8x25	DIN7984 M10x35
2	Shaft screw	ISO 4762 M6x12	ISO 4762 M6x12	ISO 4762 M8x20
3	Front plate	BF01-37 0150-5112	BF01-37 0150-5112	BF01-48 0150-5110
4	Slider	PL01-19x...	PL01-19x...	PL01-27x...
5	Hardened steel shafts for ball bearings	HL01-12x390 HL01-12x490 HL01-12x590	HL01-12x490 HL01-12x590 HL01-12x690	HL01-16x397 HL01-16x487 HL01-16x607 HL01-16x697
	Stainless steel shafts for plain bushings GF	HL01-12x390-GF HL01-12x490-GF HL01-12x590-GF	HL01-12x490-GF HL01-12x590-GF HL01-12x690-GF	HL01-16x397-GF HL01-16x487-GF HL01-16x607-GF HL01-16x697-GF
6	Clamping screw	ISO 4762 M5x18	ISO 4762 M5x18	ISO 4762 M6x25
7	Clamping cylinder	HZ01-23/37 0150-5053	HZ01-23/37 0150-5053	HZ01-48 0150-5086
8	Stator	PS01-37x120...	PS01-37x240...	PS01-48x240...
9	Shaft screw	ISO 4762 M6x12	ISO 4762 M6x12	ISO 4762 M8x20
10	Front plate	BR01-37 0150-5113	BR01-37 0150-5113	BR01-48 0150-5111
11	Rear end stop			
12	Guide block with ball bearings	HS01-37x166 0150-5002	HS01-37x286 0150-5003	HS01-48x250 0150-5088
	Guide block with plain bushings GF	HS01-37x166-GF 0150-5062	HS01-37x286-GF 0150-5063	HS01-48x250-GF 0150-5089
13	Brake hole cap	HDPE 20mm	HDPE 20mm	HDPE 24mm
	Ball bearing	SKF LBBR12-LS	SKF LBBR12-LS	SKF LBBR12-LS
	Plain bushings GF	HGF01-37	HGF01-37	HGF01-48
<b>Fan</b>				
14	Set	HV01-37/48 0150-5051	HV01-37/48 0150-5051	HV01-37/48 0150-5051
<b>Brake</b>				
15	Pneumatic brake	HB01-37 0150-5052	HB01-37 0150-5052	HB01-48 0150-5098
<b>Magspring</b>				
16	Flange	MF01-37/H37 0250-2307	MF01-37/H37 0250-2307	MF01-37/H37 0250-2307
17	Adapter	MA01-37/H37 0250-0117	MA01-37/H37 0250-0117	MA01-37/H48 0250-0118
<b>Accessories</b>				
18	Sliding Block	-	-	PFN01-8/M6 0150-3245
19	Center Sleeve	HC01-09/04 0150-3251	HC01-09/04 0150-3251	HC01-11/05 0150-3252
20	Wiper	HA01-37/19-F 0150-5177	HA01-37/19-F 0150-5177	HA01-48/27-F 0150-5178